

SOLAR CELLS - Product code: CTJ-28%

Triple-Junction Solar Cell for Space Applications

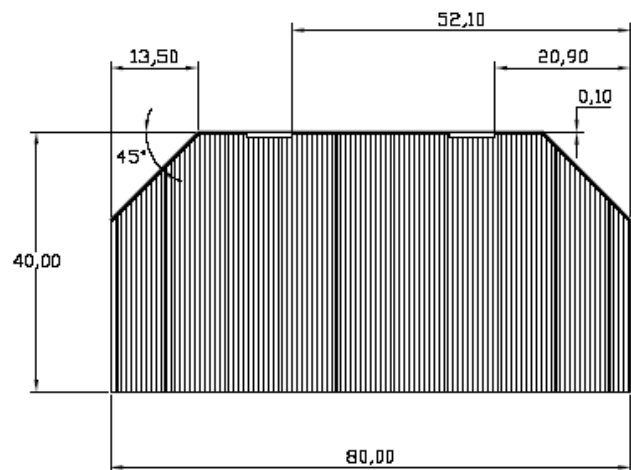
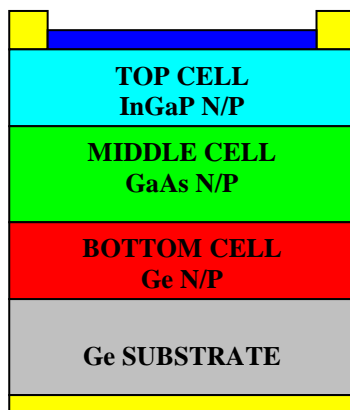

FEATURES & CHARACTERISTICS

- Triple Junction Solar Cells InGaP/GaAs/Ge for Space Applications. Polarity N on P.
- Very low solar cell mass (81-87 mg/cm²)
- Thickness 150 μm ± 30 μm.
- Minimum average efficiency 27.5%
- Fully qualified under ESA Standard ECSS E20-08 bare and CIC's
- External By-pass diode for reverse bias protection
- Weldable or Solderable Contacts, Front and Back, based on gold coated silver layers.
- Standard Dimensions from 26.5 cm² and 30.15 cm²
- Customer Specific Sizes Available
- Good mechanical strength
- Flight heritage since 2008

PERFORMANCE DATA

Solar cell electrical output parameters @AM0, T=25°C

Area (cm ²)	Isc (A)	Voc (V)	Pm (W)	FF	Eff (%)
26.5	455	2.6	1.0	0.86	28.0
30.15	522	2.6	1.2	0.86	28.0

Typical Current-Voltage Characteristic

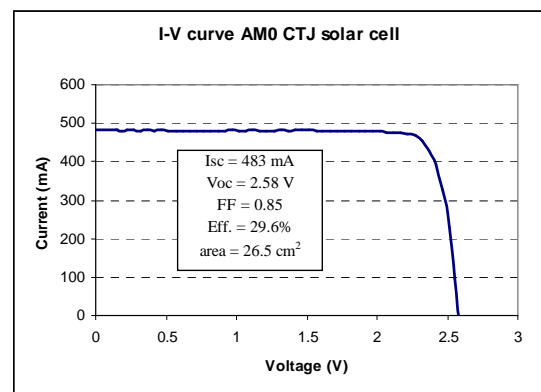

SPECTRAL RESPONSE

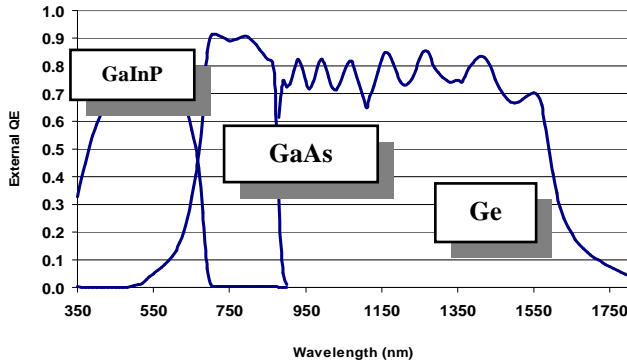

TEMPERATURE COEFFICIENTS

Temperature Dependence (0°-80°C)

$\Delta J_{sc}/\Delta T$	$\Delta V_{oc}/\Delta T$	$\Delta J_m/\Delta T$	$\Delta V_m/\Delta T$	$\Delta Eff/\Delta T$
$\mu A/cm^2/^\circ C$	mV/°C	$\mu A/cm^2/^\circ C$	mV/°C	abs.%/°C
11.17	-5.21	10.00	-5.20	-0.05

RADIATION DEGRADATION

1 MeV Electron Irradiation, EOL/BOL Ratios

Fluence (e-/cm ²)	Isc/Isc ₀	Voc/Voc ₀	Im/Im ₀	Vm/Vm ₀	Pm/Pm ₀
1.00E+14	0.98	0.98	0.97	0.99	0.96
5.00E+14	0.91	0.96	0.90	0.96	0.86

KEY SPACE QUALIFICATION RESULTS

- Metal Contact thickness 5-10 μm
- Degradation after reverse bias < 1%
- Contact Pull Strength >500 gr
- Degradation Humidity and Temperature <1%
- Solar Absorptance 0.92
- Emittance (normal) 0.85

The Information contained on this sheet is for reference only. Specification subject to change without notice.

CESI

Via Rubattino 54
 I-20134 Milano - Italy
 Tel +39 02 21251
 Fax +39 02 21255440
 e-mail: info@cesi.it
 www.cesi.it